



**We support your business
beginning to end.**

JOHNSEN MACHINE COMPANY

AUTOMATIC MASTER ICE BALER

This reliable, fully automatic machine bales pre-packaged ice products of many sizes and types.

Dimensions:

- 139" - 270" L (Depending on Configuration) X 42 3/4" W X 102" - 108" H (Depending on Configuration)
- Shipping Weight — 2,500 Pounds
- Power Requirements — 230, 460, 550V (208 Volts Min.)/3ph.60 Hz
- Air Requirements — 5 CFM @ 80 PSI
- Capacity — Up to 10 Master Bags/Minute

**Dimensions are approximate and for reference purposes only; talk to your Modern Ice representative for full engineering details.*



We don't just sell equipment.

We offer custom solutions that solve problems today and support your operation in the future!

THE MODERN DIFFERENCE

Our team of specialists and resources can help you get the most value out of your ice plant!

- Every plant is unique. We have the experience to offer the right solution.
- Engineering skills to create the most efficient and effective design for your plant.
- Service programs available to extend equipment life and maintain peak performance.
- Our unique Rent-A-Tech service program offers peace of mind when you need it.

1.513.367.2101 | 1.800.543.1581 | www.modernice.com

Modern Ice Equipment and Supply | "Order by 4:00 and Out the Door"

All Specifications Provided by Manufacturer

JOHNSEN MACHINE COMPANY

AUTOMATIC MASTER ICE BALER

Features:

- Counts & Accumulates Pre-Packaged Ice to Fill Master Poly Bags
- OMRON Programmable Logic Controller Boosts Productivity, Minimizes Manual Labor
- Presents Upright Bag into Closing System on a Conveyor
- Uniform Master Bags Allow Easier Palletizing, Save Warehouse Space
- All Adjustments Can Be Made from Touch Screen
- Design Speeds Up Bag Changeover

Options:

- Easily Customized for Any Application
- Inclined or Reversed Configuration
- Stainless-Steel Frame, Conveyor & Components
- JMC Space Saver Incline Conveyor & Bypass System
- JMC FuseAire 4 Heat Sealer
- JMC Bale Kicker, Spare Parts & Mobility Kits
- Bag Sense — "No Bag, No Dump"

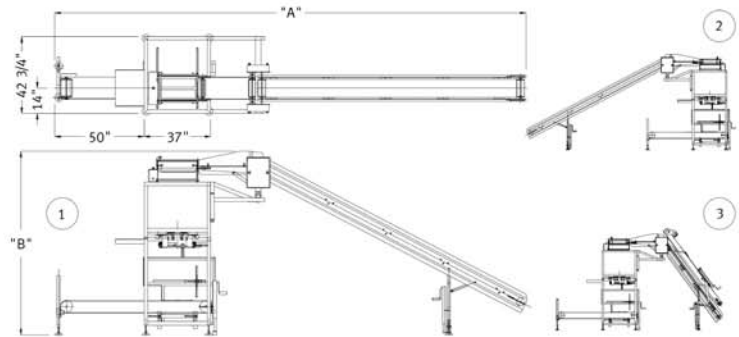

	DIMENSION "A"	APPROX. DIMENSION "B"
FIGURE 1	261" TO 270"	102
FIGURE 2	220" TO 229"	102
FIGURE 3	170" TO 192"	108
FIGURE 4	139" TO 152"	108

FUSEAIRE 4 HEAT SEALER

This simple, user-friendly system uses compressed hot air to weld both product and bale bags closed.

Dimensions:

- 29" L X 36" W X 29"-52" H (Adjustable Head)
- Shipping Weight — 475 Pounds
- Power Requirements — 115V/10 Amp
- Air Requirements — 0.9 CFM @ 80 PSI
- Conveyor Speeds — 5-125 FPM

**Dimensions are approximate and for reference purposes only; talk to your Modern Ice representative for full engineering details.*

Options:

- Resettable Counter
- Extended In-Feed for Special Handling Requirements
- Transport Conveyor for Product Support During Sealing
- Bag Top Trimmer
- Stainless-Steel Stand & Control Panel

Features:

- Complements Most Bagging Lines, with No Need for Wire or Staples
- Cost-Efficient V-Belt Bag Guide Transport
- Quick-Release Mechanism for Easy Maintenance
- Perfect for Food-Grade Application
- No Foreign Closure Materials
- Easy-Access Controls & Built-In Safety Features
- Rugged, Stainless-Steel Head
- Continuous Sealing

