

# Automatic Bulk Ice Bagger



Touch Screen



BB 1600 WITH  
MOBILITY KIT

Automatic Bulk Bagger capable of receiving a large volume of product into a poly bag.

#### FEATURES and BENEFITS:

- Save manual labour
- Fully automatic
- Fast bag changeover
- Proven technology and reliable performance
- Customized to suit applications
- Machine sets bagging pace
- Fast pay back

2 year limited warranty on JMC parts.

#### MODELS

BB 1600  
BB 1700

At JMC Innovation Never Stops



SINCE 1961

Adjustable Automatic Master Balers • Wicketed Baggers • Hot Air Sealers

# Automatic Bulk Ice Bagger

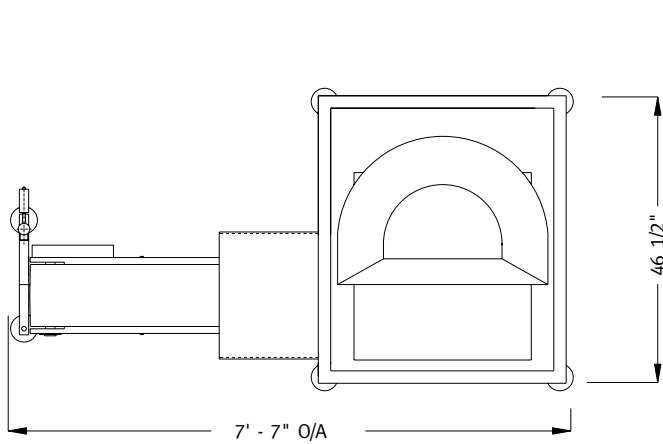

MODEL:	CLAMSHELL	BAG FACE SIZE RANGE
BB 1600	6 INCH	12" TO 17"
BB 1700	7 INCH	14" TO 20"

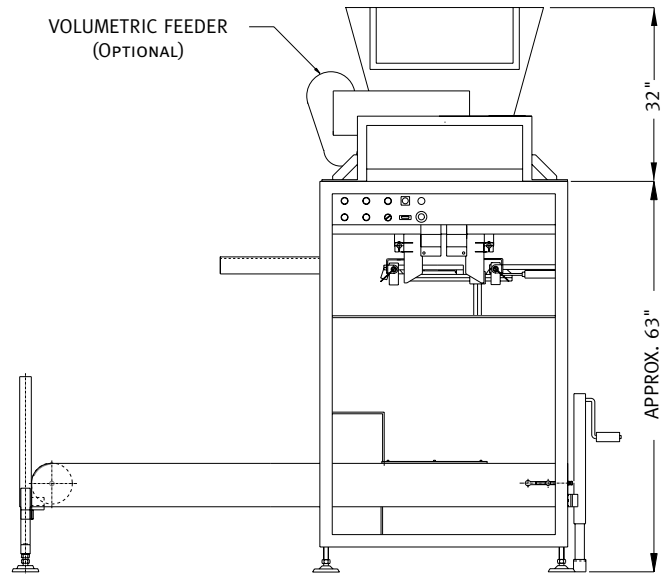

Automatic Wicketed Bagger which is designed to open the Master Bag to receive a charge from the volumetric feeder and then automatically present the upright bag into a closing station.

## STANDARD FEATURES:

- P.L.C. (programmable logic controller)
- Adjustable conveyor height
- Adjustable bag wicket
- Bag inflation system
- Bale pusher with bag transport grippers
- Take away conveyor
- Stainless steel panels and contact parts
- Integral electrical control panel
- Leveling feet
- Bagging speed selectable on touch screen
- Bag sense "no bag-no dump"
- Volumetric feeder
- Stainless steel finish

## OPTIONS:

- FuseAire 4 Hot Air Sealer
- JMC Bag Kicker with longer T.A.C. to accommodate palletizer
- Spare Parts Kit
- Mobility Kit
- Epoxy powder baked finish

## SPECIFICATIONS:

Power - 230/460/550 V, 3 PH, 60 HZ (minimum 208 V)  
 Air - 4 CFM @ 80 PSI  
 Shipping weight - Approx. 1200 lbs.  
 Capacity of volumetric-adjustable up to 10lb maximum per dump